

1

2

3

4

A

A

B

B

C

C

D

D

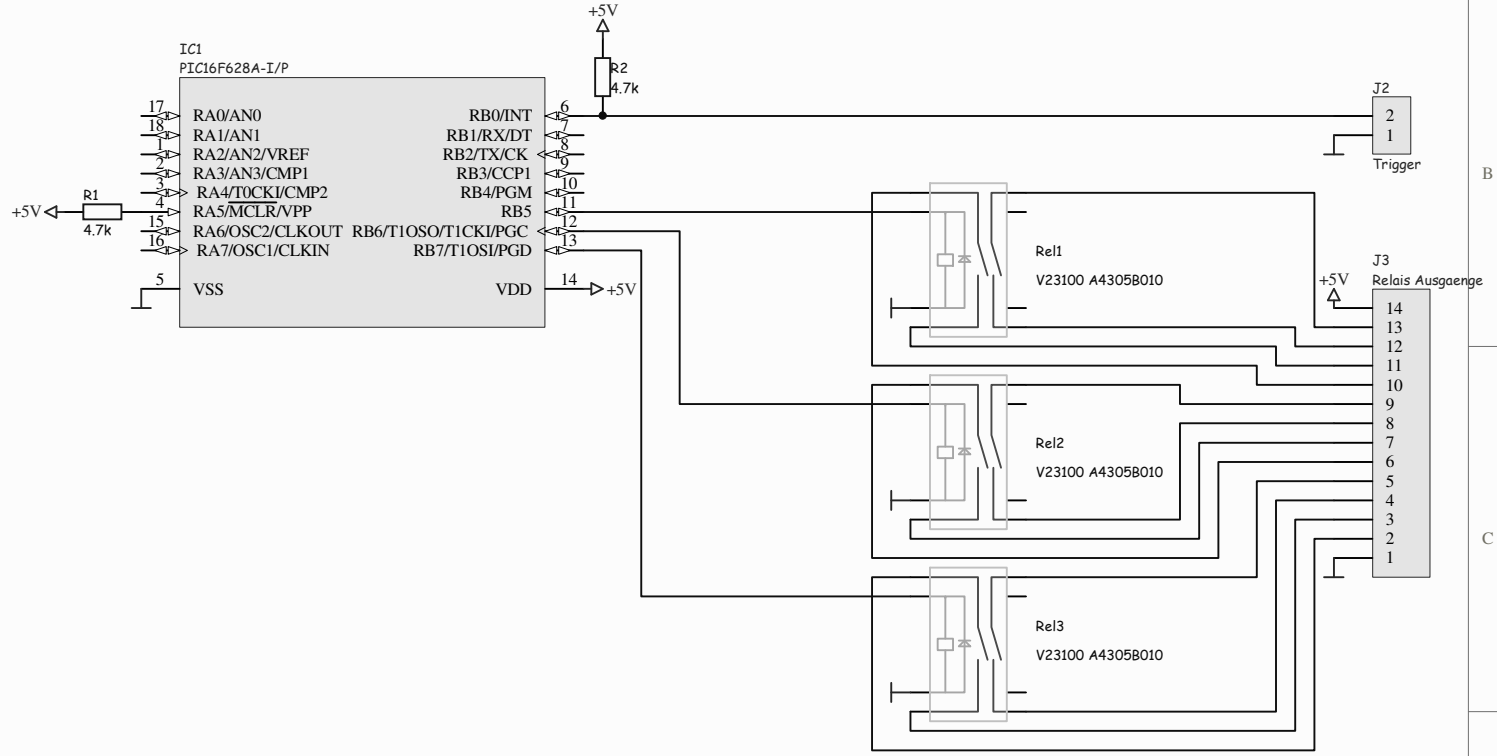
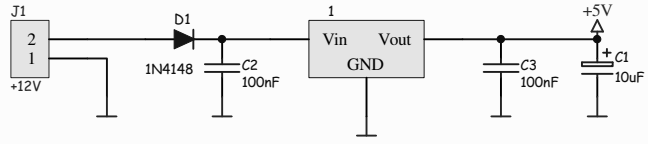

1

2

3

4

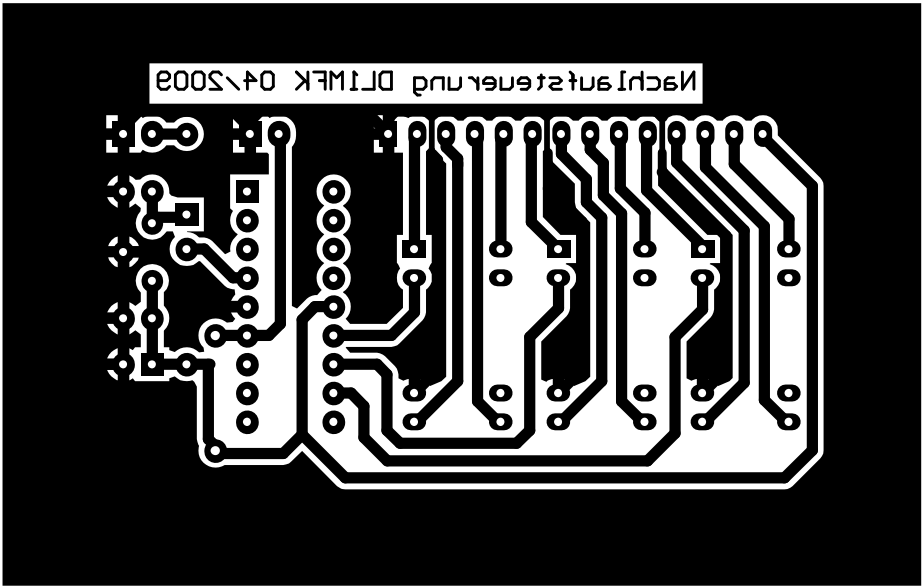

Nachsteuerung und DIMK 04/2009

